



CAMMA MASC

TRANCIATURA MECCANICA

MECHANIC SHEARING

MECHANISCHE STANZEINHEIT/SCHIEBER

CARROS DE PUNZONADO



Camma meccanica di potenza fino a 40000 daN con un ritorno garantito mediante due molle ad azoto, su cui vengono applicati gli accessori o gli acciai per eseguire le lavorazioni desiderate. Il moto è trasferito mediante cunei inclinati ed è dotato di un sistema antirotativo. Può essere montata in posizione orizzontale o inclinata (previo confronto con l'ufficio tecnico Newstark). Possibili applicazioni: adatta a lavori generalmente di tranciatura, foratura e piegatura.

Mechanical cam with power supply up to 40000 daN with return by nitrogen spring, on which are applied accessories or steel, to perform required work. The motion is transferred through wedges inclined and in which there is an anti-rotation system. Can be fitted horizontally or inclined (after comparison with Newstark's technical department). Means of application: generally suitable for shearing, drilling and bending work.

Mechanische Stanzeinheit Kraft bis 40000 daN mit einem Rücklauf der durch Stickstoffedern sichergestellt wird. An der Schubstange kann Zubehör je nach Bedarf angebracht werden. Bei diesem Modell, wird die Bewegung durch Keile umgesetzt. Durch die Art der Schubstange wird die Rotationsbewegung so gering wie möglich gehalten. Diese Einheit ist für die Montage von oben ausgelegt. Die Einheiten können (nach Abstimmung mit technischen Büro von Newstark) horizontal oder geneigt montiert werden. Mögliche Anwendungen: Stanzen, Biegen und Prägen.

Unidad de punzonado de hasta 40000 daN con retroceso por cilindro de nitrógeno. Debido a su resistencia estructural proporciona un mayor rendimiento a comparación con el modelo M y ML. Mucho más potente en comparación con el modelo MA ya que la transmisión es a través de un sistema de cuñas. Se puede montar horizontalmente o inclinado (después de la comparación con el departamento técnico de Newstark). Adecuado para trabajos de corte, taladrado y plegado.

CAMMA MASC

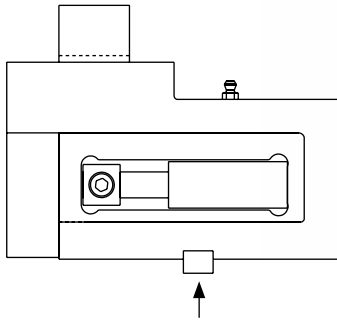

Si consiglia il montaggio con chiave reggispinta.
We suggest you to assembly by using a thrust mount key.
Es wird empfohlen, die Montage mit einem Gegenlager vorzunehmen.
Se aconseja el montaje siempre con el pasador.



Il sistema monta un congegno elettronico miniaturizzato (P8) per il controllo del corretto riposizionamento dell'attrezzatura.
The system fits a miniaturized electronic device (P8) to control the correct repositioning of the equipment.
Das System ist mit einem elektronischen Sensor (P8) für die Nullstellung des Systems ausgerüstet.
El sistema cuenta con un mini dispositivo electrónico "P8" para garantizar el perfecto reposicionamiento del sistema.

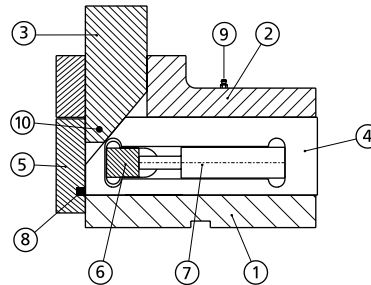
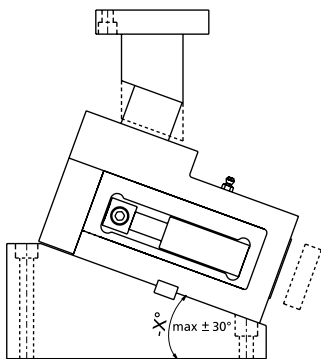
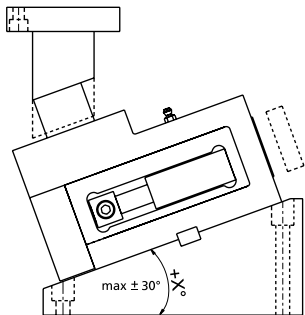

POSIZIONE - POSITION POSITION - POSICIÓN	QUANTITÀ - QUANTITY MENGE - CANTIDAD	DESCRIZIONE - DESCRIPTION - BESCHREIBUNG - DESCRIPCIÓN
001	1	Corpo camma / Cam body / Grundgehäuse / Cuerpo
002	1	Coperchio / Cover / Kopfplatte / Cubierta
003	1	Cuneo / Wedge / Druckkeil / Cuña
004	1	Slitta / Slider / Lagerkeil / Deslizador
005	1	Flangia Posteriore / Rear flange Hinterer Flansch / Brida trasera
006	2	Blocchetto reggi molla / Spring holder block Federlagerblock / Muelle de bloque primario
007	2	Cilindro ad azoto / Nitrogen cylinder Stickstoffzylinder / Cilindro de nitrógeno
008*	1	Micro sensore di sicurezza / Micro sensor for security Elektronischer Sensor für Sicherheit / Microsensor de seguridad
09	2	Ingrassatore / Nipples / Schmierung / Engrasadores
010	1	Perno / Pin / Stift / Perno

* OPTIONAL DA RICHIEDERE IN FASE D'ORDINE - OPTIONAL TO BE REQUESTED DURING ORDER
IST ALS OPTION ERHÄLTlich - OPCIONAL, PARA SOLICITAR EN FASE DE PEDIDO

ESEMPIO D'ORDINE RICAMBIO - SPARE PART ORDER EXAMPLE
BESTELLBEISPIEL EINZELTEILE - EJEMPLO DE PEDIDO DE RECAMBIOS

MASC 400 S48

MODELLO - MODEL
MODELL - MODELO

+10°

INCLINAZIONE - SLOPE
NEIGUNG - INCLINACIÓN

002

POSIZIONE - POSITION
POSITION - POSICIÓN

PER APPLICAZIONI INCLINATE CONSULTARE IL NOSTRO UFFICIO TECNICO.
FOR THE POSSIBLE INCLINED APPLICATIONS CONSULT OUR TECHNICAL DEPARTMENT.
FÜR GENEIGTE ANWENDUNGEN SETZEN SIE SICH BITTE MIT DEM TECHNISCHEN BÜRO IN VERBINDUNG.
PARA APLICACIONES INCLINADAS CONSULTAR CON EL DEPARTAMENTO TÉCNICO.



CAMMA MASC

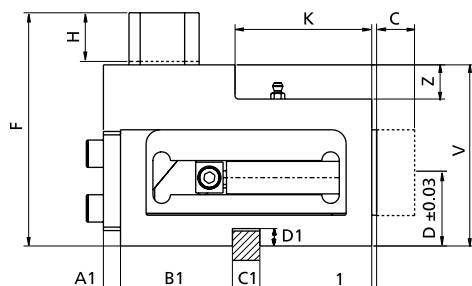
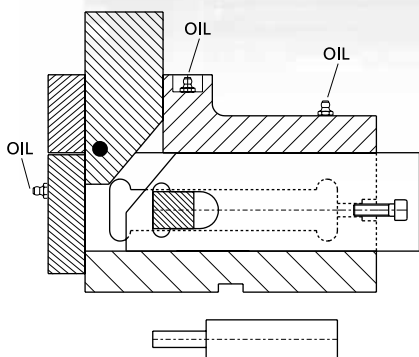

Attenzione: per eseguire la prova manualmente togliere il cilindro come indicato.
 Attention: in order to manually perform the test, extract the cylinder as indicated.
 Achtung: Stickstoffzylinder verbaut, Schieber nur in Grundstellung öffnen.
 Para llevar a cabo la prueba manualmente, extraer el cilindro como se indica.

! Si prega di consultare il nostro manuale di uso e manutenzione!
 Please consult our Instruction Manual!
 Bitte beachten Sie unsere Wartungsanweisung!
 Por favor, consulte nuestro manual de instrucciones!

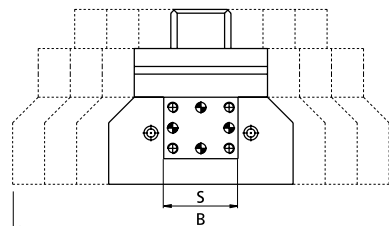
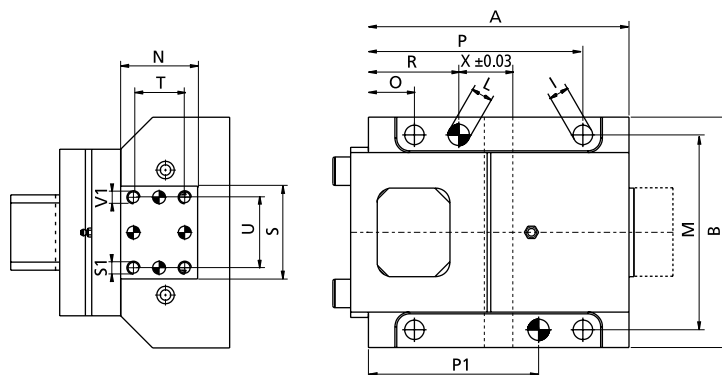

B/S
 Larghezza modulare
 Modular Width
 Modulare Breite
 Largo modular

ESEMPIO D'ORDINE - ORDER EXAMPLE
 BESTELLBEISPIEL - EJEMPLO DE PEDIDO

MASC 400 S48 **+10°**
 MODELLO - MODEL INCLINAZIONE - SLOPE
 MODELL - MODELO NEIGUNG - INCLINACIÓN

DATI TECNICI MODELLO ESTRAZIONE MAX (daN) / TECHNICAL DATA OF THE MAX EXTRACTION MODEL (daN) / TECHNISCHE DATEN DES MODELLS MIT MAXIMALER RÜCKZUGSKRAFT (daN) / DATOS TÉCNICOS MODELO EXTRACCIÓN MAX (DAN)

MODELLO e forza iniziale di estrazione in daN MODEL and initial extraction force in daN MODELL und Rückzugskraft in daN MODELO y fuerza de extracción inicial en daN	A	A1	B	B1	C	C1	D	D1	F	H	I	L ^{+0,02 0}	M	N	O	P	P1	R	S	T	U	Z	s1 ^{+0,02 0}	V	V1	K	X	Sforzo max trancio daN Cutting max force daN Maximale Schnittkraft daN Max fuerza de corte daN
MASC 400 S48	142	18	130	65	24	12	44	4	137	29	M10	Ø 12	110	48	26	116	91	51	48	32	34	20	Ø 8	106	M8	80	26	8000
MASC 400 S98	142	18	180	65	24	12	44	4	137	29	M10	Ø 12	160	48	26	116	91	51	98	32	84	20	Ø 8	106	M8	80	26	8000
MASC 400 S148	142	18	230	65	24	12	44	4	137	29	M10	Ø 12	210	48	26	116	91	51	148	32	134	20	Ø 8	106	M8	80	26	8000
MASC 400 S198	142	18	280	65	24	12	44	4	137	29	M10	Ø 12	260	48	26	116	91	51	198	32	184	20	Ø 8	106	M8	80	26	8000
MASC 900 S58	150	28	144	67	24	16	44	4.5	137	29	M10	Ø 12	124	48	26	121	96	51	58	32	44	20	Ø 8	106	M8	88	32	14000
MASC 900 S108	150	28	194	67	24	16	44	4.5	137	29	M10	Ø 12	174	48	26	121	96	51	108	32	94	20	Ø 8	106	M8	88	32	14000
MASC 900 S158	150	28	244	67	24	16	44	4.5	137	29	M10	Ø 12	224	48	26	121	96	51	158	32	144	20	Ø 8	106	M8	88	32	14000
MASC 900 S208	150	28	294	67	24	16	44	4.5	137	29	M10	Ø 12	274	48	26	121	96	51	208	32	194	20	Ø 8	106	M8	88	32	14000
MASC 1500 S88	217	38	196	113.5	36	20	60.5	5.5	195	43	M12	Ø 16	172	75	65	182	157	90	88	54	69	20	Ø 12	146	M12	111.5	43.5	20000
MASC 1500 S138	217	38	246	113.5	36	20	60.5	5.5	195	43	M12	Ø 16	222	75	65	182	157	90	138	54	119	20	Ø 12	146	M12	111.5	43.5	20000
MASC 3000 S118	247	48	266	124.5	36	28	81	7	244	51.5	M16	Ø 16	236	94	75	202	172	105	118	68	94	20	Ø 16	186	M12	126.5	47.5	40000
MASC 3000 S168	247	48	316	124.5	36	28	81	7	244	51.5	M16	Ø 16	286	94	75	202	172	105	168	68	144	20	Ø 16	186	M12	126.5	47.5	40000